

MANUFACTURERS
"AFC" LOGO
.025 MAX
RAISED OR INDENTED

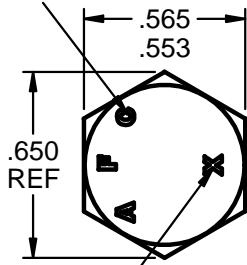

"X" ALLOY STEEL
GRADE MARK

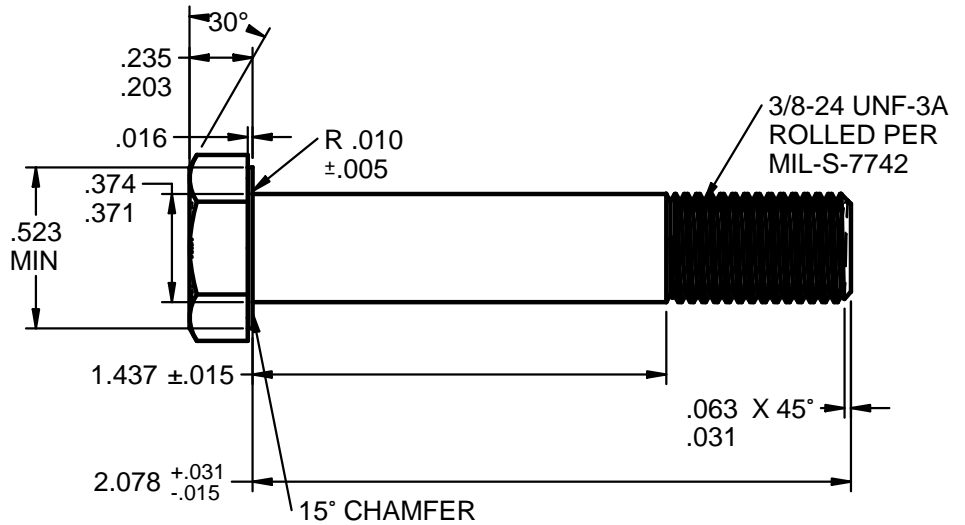

SCALE: 1.5X

DESIGN NOTES: AN6-20A AIRFRAME BOLT

1. LENGTH 2-5/64" (2.078"), GRIP 1-7/16" (1.437"), THREAD 3/8-24 UNF-3A.
2. PROCUREMENT SPECIFICATION NASM6812.
3. MATERIAL ALLOY STEEL PER PROCUREMENT SPECIFICATION.
UNS G40370 AMS6300 DFAR EXEMPT
UNS G87400 AMS6322 DFAR APPLIES
UNS G41400 AMS6382 DFAR APPLIES
UNS G41300 AMS-S-6758 DFAR APPLIES
4. HEAT TREAT AMS-2759 HRC 26-32.
5. FINISH CADMIUM PLATED PER AMS-QQ-P-416, TYPE 2 (YELLOW), CLASS 2.
6. THREADS 3/8-24 UNF-3A ROLLED PROCESS PER MIL-S-7742.
7. TENSILE 10,100 LBS. [44,927 N] MIN.
8. YIELD 7,740 LBS. [34,429 N] MIN.
9. SINGLE SHEAR 8,280 LBS. [36,831 N] MIN. SHORT LENGTH N/A.

EXAMPLE PART NUMBER

AFC 6-20 C2 CADMIUM TYPE 2 YELLOW PLATING
AFC 6-20 C1 CADMIUM TYPE 1 PLAIN WHITE PLATING
AFC 6-20 TDC THERMAL DIFFUSION COATED ASTM A1059

↑ FINISH
↑ LENGTH 2.078"
↑ BODY SIZE & THREAD .375-24 UNF-3A
↑ MANUFACTURER AIRFASCO



ACTUAL SIZE

UNCONTROLLED

CONFORMS TO: NASM3 THRU NASM20
PART NUMBER: AN6-20A

DIMENSIONS ARE IN INCHES AND TOLERANCES ARE AS SHOWN BELOW. DIMENSIONAL TOLERANCES AND SYMBOLS PER ANSI Y14.5M-1982	PROPRIETARY PARTS SHOWN IN THIS DRAWING ARE THE SUBJECT OF ISSUED UNITED STATES AND FOREIGN PATENTS AND PATENTS PENDING. UNAUTHORIZED REPRODUCTION AND/OR DISTRIBUTION OF THIS DRAWING IS STRICTLY PROHIBITED.		AIRFASCO.com 2655 HARRISON AVE SW, CANTON, OHIO 44706 USA	
	APPROVALS DRAWN M.B. DATE 3/10/14 CHECKED T.W. DATE 3/10/14 ENG APPR B.E. DATE 3/10/14 MGR APPR D.D. DATE 3/10/14		PART NUMBER: AN6-20A_AFC6-20C2 SIZE A MATERIAL: 4037 / 8740 OR AS NOTED EST. WEIGHT: .077 / EACH LBS. [35.1 g]	
ANGLES ±5° .XX ±.03" .XXX ±.010" .XXXX ±.001"	SCALE: 1.5X DRAWING NUMBER: AN6-20A_AFC6-20C2		SHEET 1 OF 1	